

COLOR CODE FOR WIRING CONNECTING TRAFFIC SIGNAL LAMPS

NOTE: No splices allowed between traffic signal head and controller.

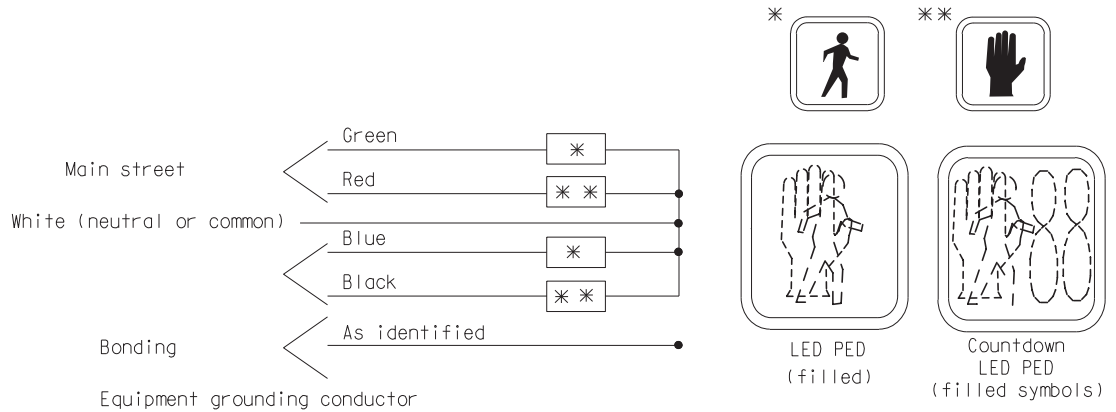

COLOR CODE FOR WIRING CONNECTING PEDESTRIAN SIGNAL LAMPS
(WALKING PERSON - HAND SYMBOL)

NOT TO SCALE

File: RefDoc/TR/Signals/Web/Sp Det/Fin/SIG230A.dgn Rev: 02/16/17



PREPARED BY
TRAFFIC AND SAFETY

DRAWN BY: DJF

CHECKED BY:

ENGINEER OF DELIVERY

ENGINEER OF DEVELOPMENT

(SPECIAL DETAIL)

FHWA APPROVAL DATE

MICHIGAN DEPARTMENT OF TRANSPORTATION
BUREAU OF HIGHWAYS DELIVERY STANDARD PLAN FOR

**COLOR CODE WIRING/
EQUIPMENT GROUNDING**

PLAN DATE

SIG-230-A

SHEET
1 of 6

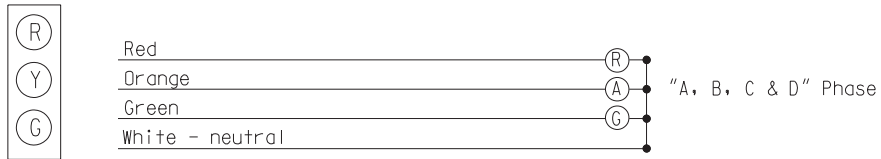

STANDARD - 3 COLOR SIGNAL DISPLAY

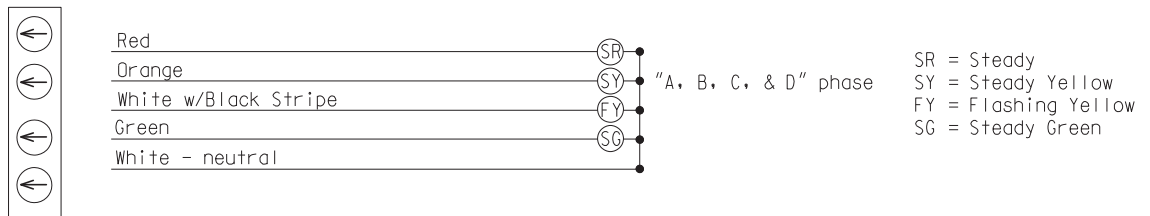

FLASHING YELLOW ARROW (FYA) - 4 COLOR SIGNAL DISPLAY

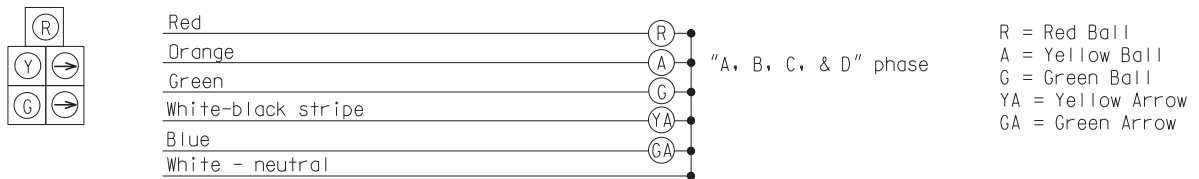

DOG HOUSE W/RIGHT TURNS - 5 COLOR SIGNAL DISPLAY

COLOR CODE FOR WIRING CONNECTING TRAFFIC SIGNAL LAMPS

NOT TO SCALE

MICHIGAN DEPARTMENT OF TRANSPORTATION
BUREAU OF HIGHWAYS DELIVERY STANDARD PLAN

(SPECIAL DETAIL)
FHWA APPROVAL DATE

File: RefDoc/TR/Signals/Web/Sp Det/Fin/SIG230A.dgn Rev. 02/16/17

PLAN DATE

SIG-230-A

SHEET
2 of 6

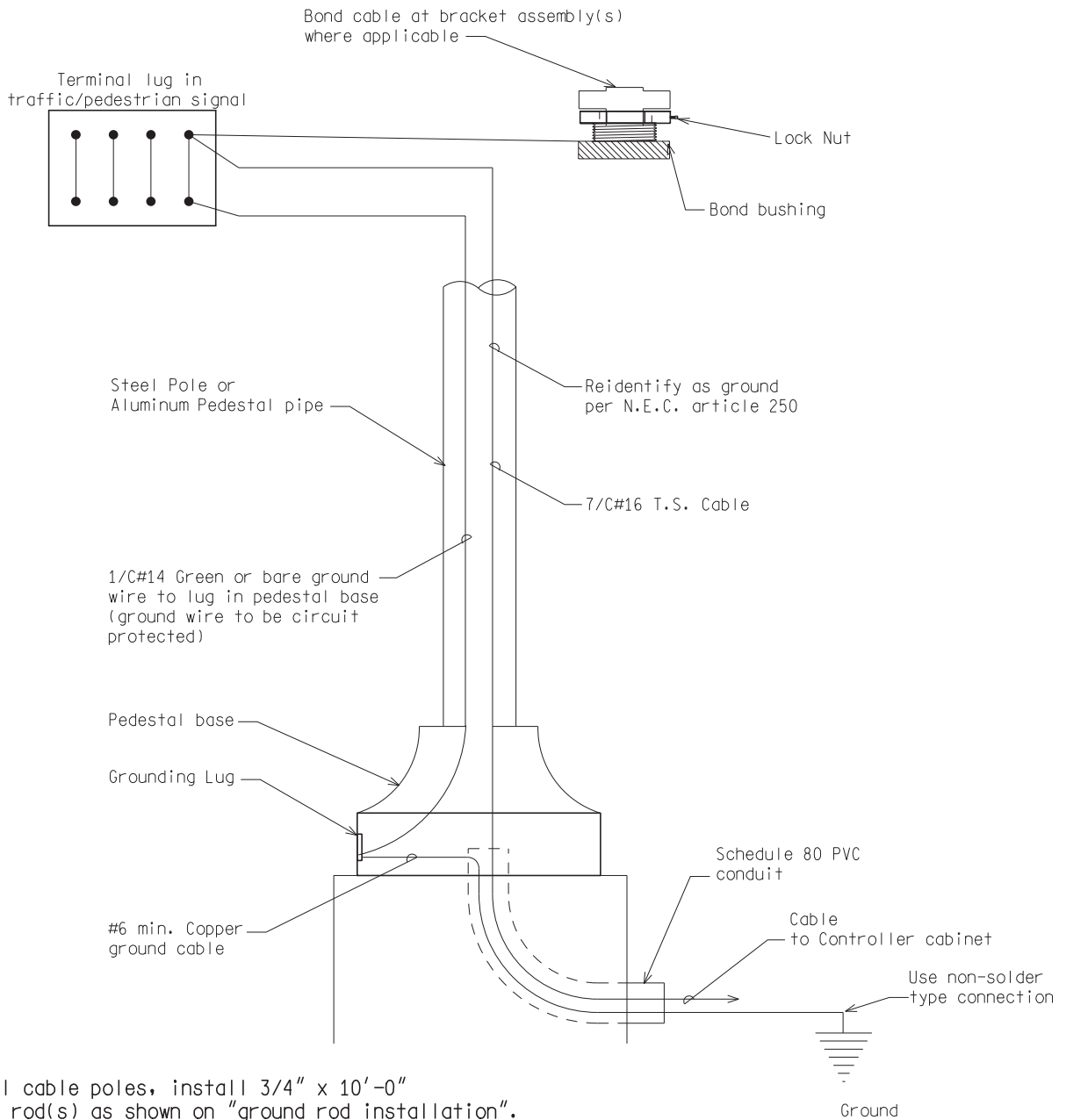

NOTE:
 For all cable poles, install 3/4" x 10'-0" ground rod(s) as shown on "ground rod installation".
 Connect ground rod(s) with #6 min. copper wire to messenger wire with non-solder type connection.

STEEL POLE/PEDESTAL GROUNDING DETAIL

NOT TO SCALE

MICHIGAN DEPARTMENT OF TRANSPORTATION
 BUREAU OF HIGHWAYS DELIVERY STANDARD PLAN

(SPECIAL DETAIL)
 FHWA APPROVAL DATE

PLAN DATE

SIG-230-A

SHEET
 3 of 6

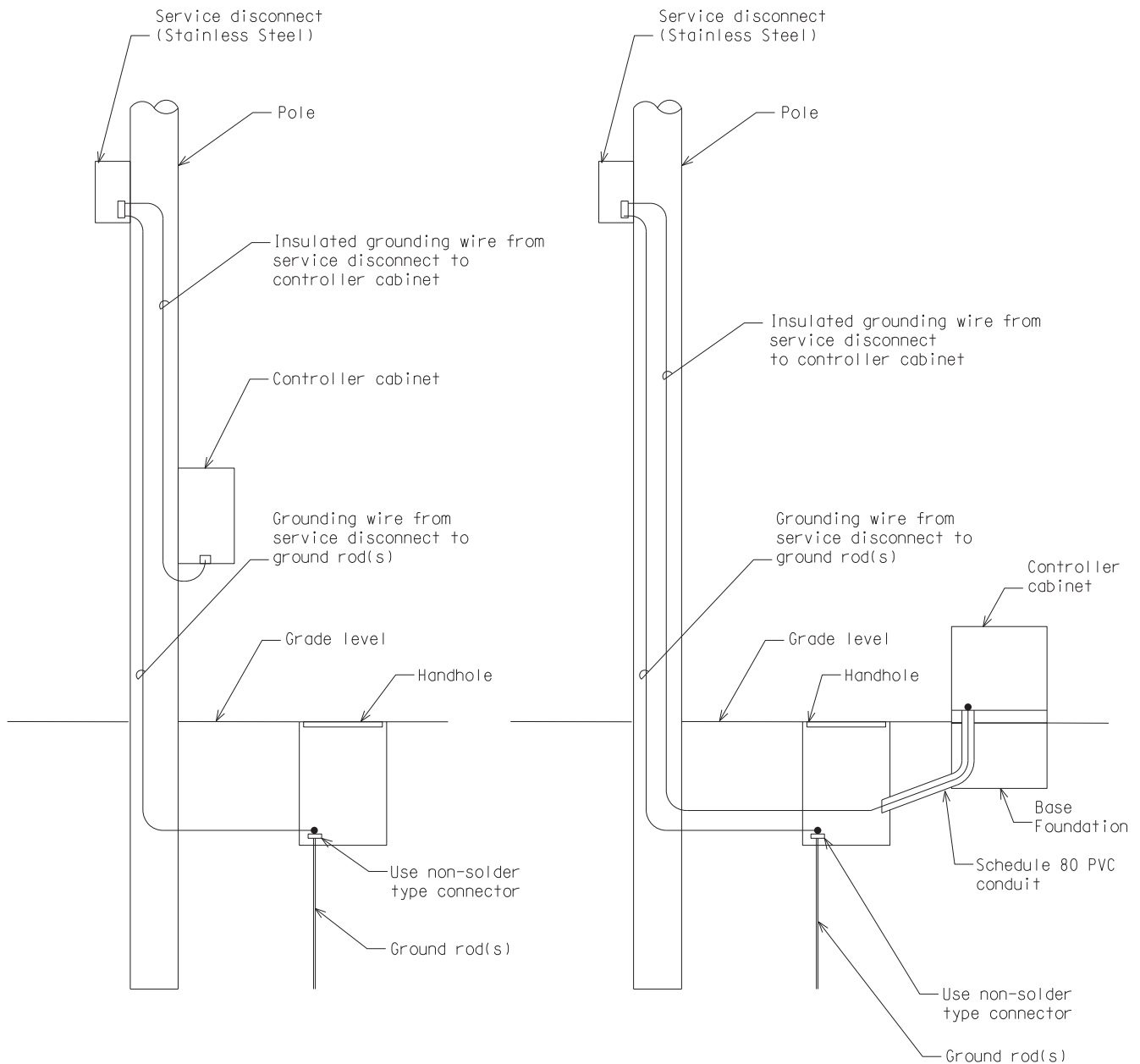

GROUNDING

Install 3/4 " x 10'-0" copper clad ground rod(s) as required to provide less than 10 OHM resistance to ground.

Grounding wire #6 AWG min. bare copper grounding wire shall be installed to meet N.E.C. and utility company specs.

Ground wire from disconnect to ground rod to be in moulding (wood pole or post) or inside the pole (steel). Ground wire from disconnect to controller cabinet to be in conduit (wood pole, wood post, and steel pole).

CONTROLLER CABINET GROUNDING DETAIL

NOT TO SCALE

MICHIGAN DEPARTMENT OF TRANSPORTATION BUREAU OF HIGHWAYS DELIVERY STANDARD PLAN	(SPECIAL DETAIL) FHWA APPROVAL DATE		SIG-230-A	SHEET 4 of 6
File: RefDoc/TR/Signals/Web/Sp Det/Fin/SIG230A.dgn Rev. 02/16/17		PLAN DATE		

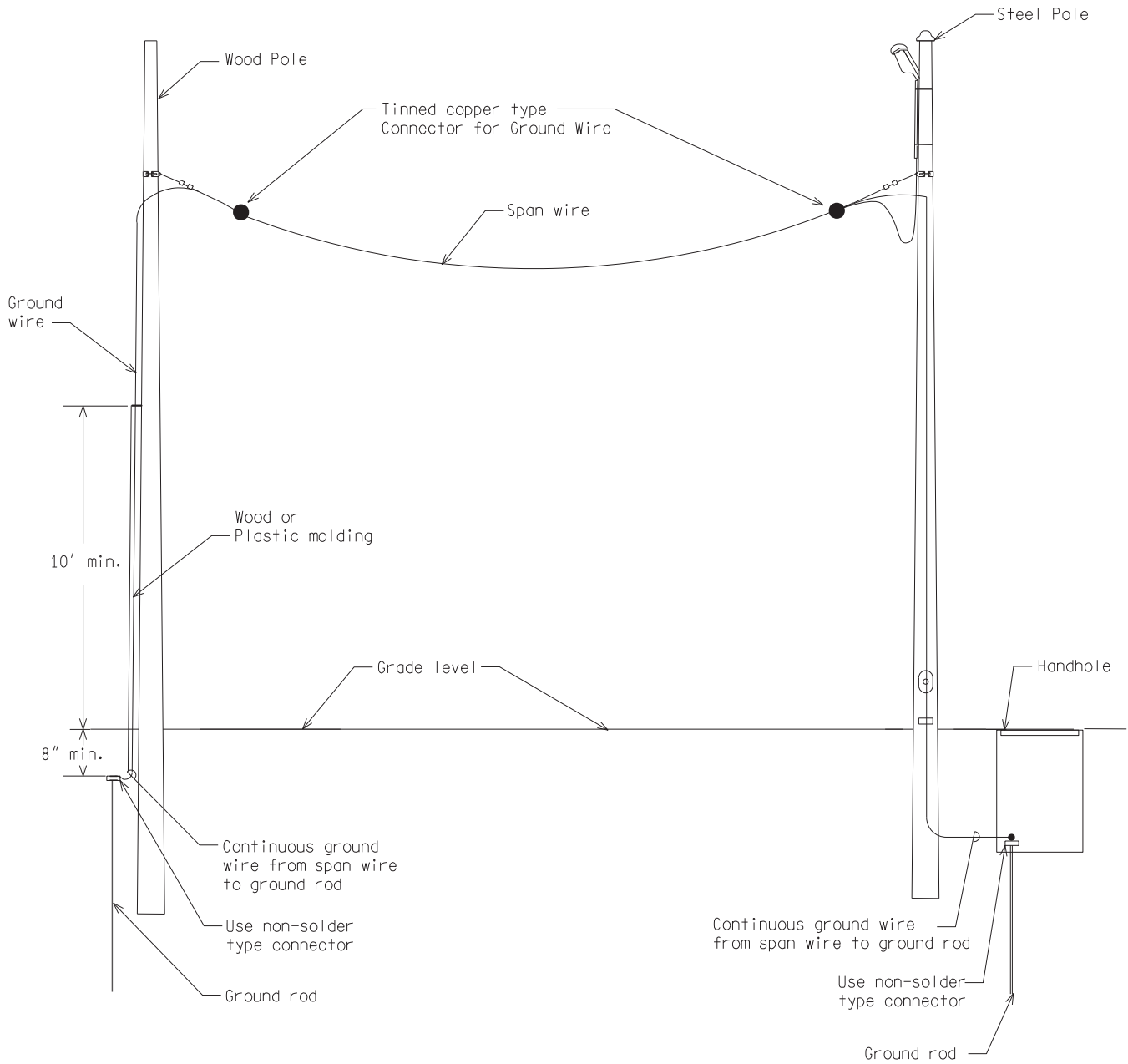

SPAN WIRE GROUNDING DETAIL

NOT TO SCALE

MICHIGAN DEPARTMENT OF TRANSPORTATION
BUREAU OF HIGHWAYS DELIVERY STANDARD PLAN

(SPECIAL DETAIL)
FHWA APPROVAL DATE

PLAN DATE

SIG-230-A

SHEET
5 of 6

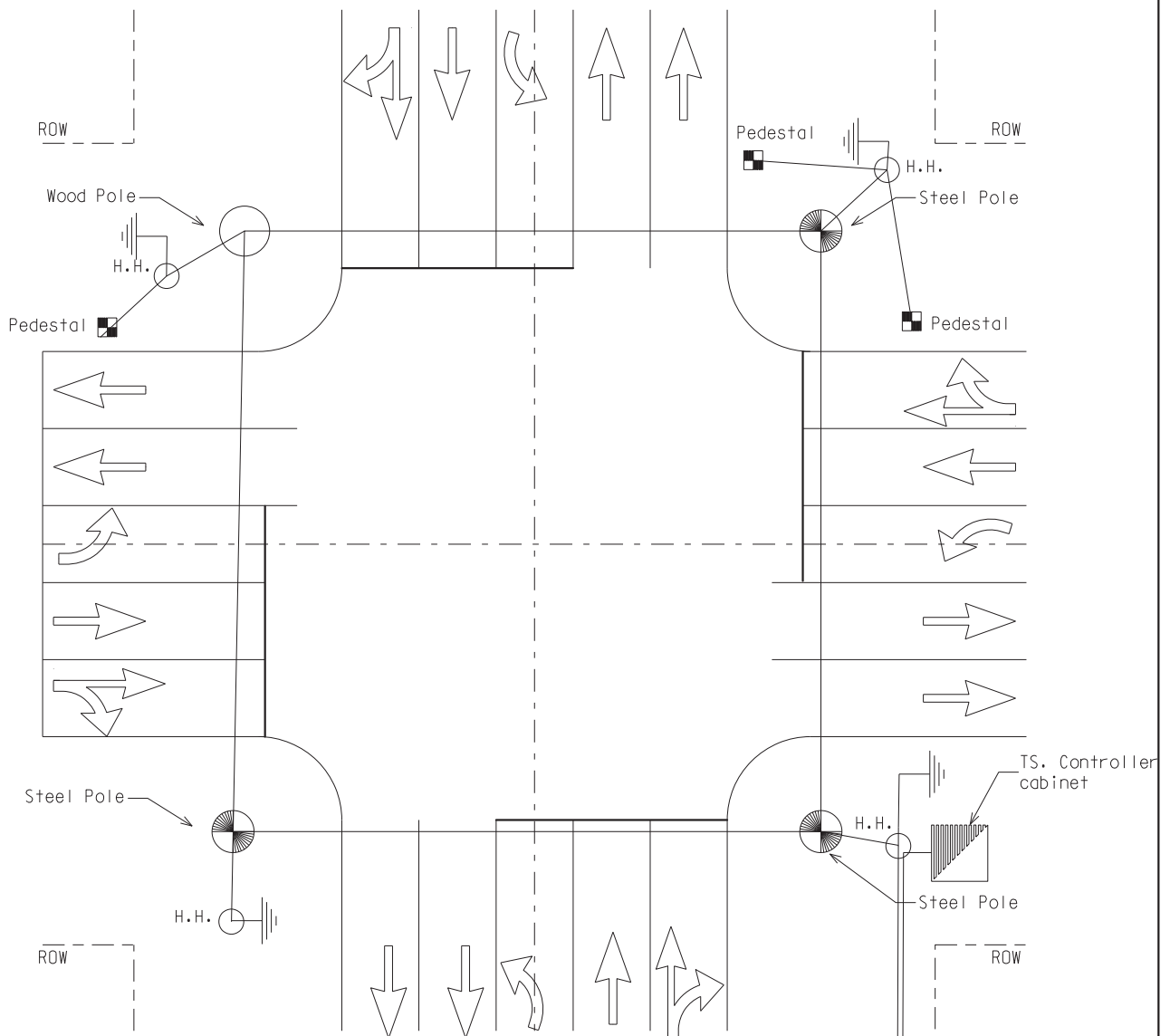

- 1) All ground rods shall be 3/4" x 10' in length copperclad.
- 2) Ground rods shall be drive straight down, so that only the required portions of of the ground rod is exposed to attach the ground wires.
- 3) All ground rods shall be connected to each other or to a span wire with a single #6 AWG copper conductor.
- 4) Each ground wire attaching to a ground rod shall have its own approved acorn type connector.
- 5) Do not install any ground rods within 10' of any other ground rods from other grounding.
- 6) The grounding system shall measure 10 ohms or less.
- 7) A separate insulated green #6 AWG copper ground is required from the service disconnect (safety switch) to the ground bussbar in the controller cabinet.
- 8) Ground rod for each steel pole, wood pole, pedestal and/or traffic signal controller cabinet shall be located in the adjacent handhole as indicated on the plans or as directed by the Engineer.
- 9) All metal bases must be connected to a ground rod with a #6 ground wire.

SYSTEM GROUNDING DETAIL

NOT TO SCALE

MICHIGAN DEPARTMENT OF TRANSPORTATION BUREAU OF HIGHWAYS DELIVERY STANDARD PLAN	(SPECIAL DETAIL) FHWA APPROVAL DATE	PLAN DATE	<h2 style="margin: 0;">SIG-230-A</h2>	SHEET 6 of 6
--	--	-----------	---------------------------------------	-----------------